



UNDERSTANDING UL 94

Test for Flammability of Plastic Materials for Parts in Devices and Appliances

UL intends this standard to serve as a preliminary indication of a plastics acceptability for use as part of a device or appliance with respect to its flammability. It is not intended to reflect the hazards of a material under actual fire conditions.

UL 94 flammability testing is the first step toward obtaining a plastic recognition and subsequent listing in the "Plastics Recognized Component Directory" (former known as "Yellow Cards"). UL 94 contains the following tests: 94HB, 94V, 94VTM, 94-5V, 94HBF, 94HF and Radiant Panel. Of these only 94HB, 94V and 94VTM apply to film products. The 94-5V is for enclosures for products that are not easily moved or are attached to a conduit system. The 94HBF and HF are used for nonstructural foam materials i.e., acoustical foam. Radiant panel test is an ASTM (E162) test to determine the flame spread of a material that may be exposed to fire.

The following is a brief description of the four tests that apply to film and foam and how the rating system works. This is **not** meant as a procedure for running the tests or a way of determining the acceptability of a material for a particular application. Those who would like more details should contact UL or obtain a copy of this and other UL Standards through Global Engineering Documents by calling 800-854-7179.

94HB HORIZONTAL BURNING TEST

This is generally considered the easiest test to pass and materials that pass any of the V or VTM tests will usually be accepted by UL for applications that require 94HB. To be sure, check with the UL representative assigned to the device in which the film will be used. The 94HB rating would typically be acceptable for **portable, attended**, intermittent-duty, household use appliance enclosures (i.e., hair dryers) or for decorative parts.

The test uses a ½"x 5" specimen held at one end in a horizontal position with marks at 25mm and 100mm from the free end. A flame is applied to the free end for 30 seconds or until the flame front reaches the 25mm mark. See fig. 1. If combustion continues the duration is timed between the 25mm mark and the 100mm mark. If combustion stops before the 100mm mark the time of combustion and the damaged length between the two marks are recorded. A set of three specimens are tested

A material that is less than 0.118" in thickness will be classified 94HB if it has a burning rate of less than 75mm per minute or stops burning before the 100mm mark. If one specimen from the set of three fails to comply then a second set of three are tested. All three of this second set must comply.

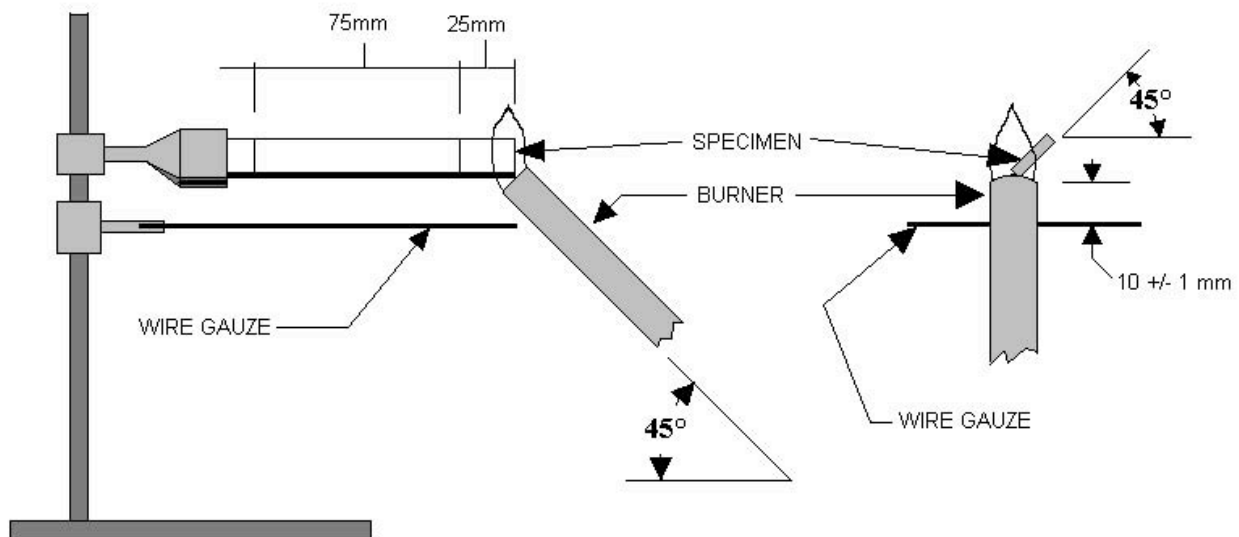

Fig 1 HORIZONTAL BURN SET-UP

94V VERTICAL BURNING TEST

This test includes three classifications – 94V-0, 94V-1 and 94V-2 – and would typically be acceptable for **portable, unattended**, intermittent-duty, household-use appliances (i.e., coffee makers). Which classification applies to a particular application depends on many factors such as:

- Size and thickness of part.
- Distance from uninsulated live parts.
- Other UL746A properties such as;
- Hot wire ignition
- High current arc ignition
- High voltage arc tracking rate
- Others

This test uses a 1/2" x 5" specimen which is held at one end in the vertical position (see fig. 2). A burner flame is applied to the free end of the specimen for two-10 second intervals separated by the time it takes for flaming combustion to cease after the first application. Two sets of 5 specimens are tested. The following are recorded for each specimen:

- Duration of flaming combustion after the first burner flame application.
- Duration of flaming combustion after second burner flame application.
- Duration of glowing combustion after second burner flame application.
- Whether or not flaming drips ignite cotton placed below specimen.
- Whether or not specimen burns up to holding clamp.

Table 1. **Material classification**

Criteria conditions	94V-0	94V-1	94V-2
Total flaming combustion for each specimen	≤ 10s	≤ 30s	≤ 30s
Total flaming combustion for all 5 specimens of any set	≤ 50s	≤ 250s	≤ 250s
Flaming and glowing combustion for each specimen after second burner flame application	≤ 30s	≤ 60s	≤ 60s
Cotton ignited by flaming drips from any specimen	NO	NO	YES
Glowing or flaming combustion of any specimen to holding clamp	NO	NO	NO

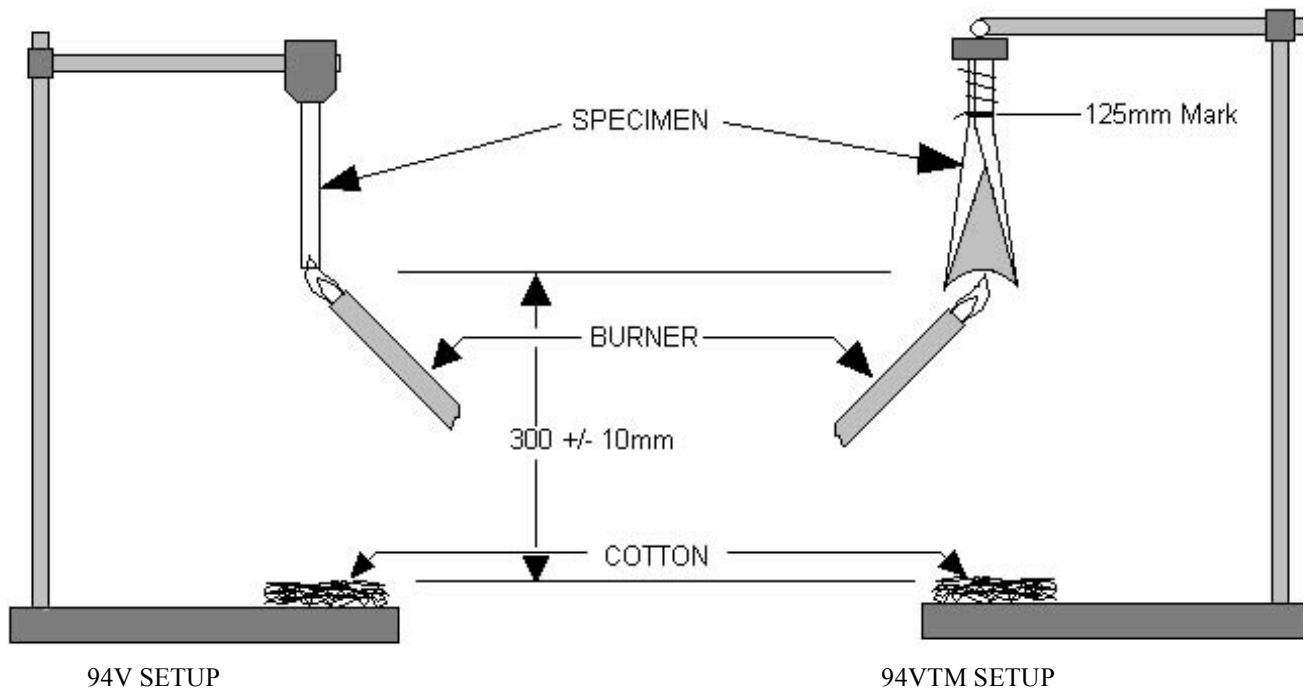

Fig. 2

94VTM THIN MATERIAL VERTICAL BURNING TEST

Materials that are thin gauge – typically ≤ 10 mil, or very flexible may distort, shrink or flex during the 94V test. These materials can be tested using 94VTM – the thin material version of the vertical burning test. This differs in several ways from the 94V test:

- The specimen size is 200mm x 50mm (8" x 2").
- The specimen is rolled longitudinally around a 13mm ($\frac{1}{2}$ ") dia. mandrel and taped on one end. When the mandrel is removed the specimen forms a cone shape, which provides rigidity to the length of the specimen. See fig. 2.
- The two flame applications have duration of three seconds instead of ten.

Although this test was designed for thinner gauge materials any material can be tested using 94VTM as long as can be formed around a $\frac{1}{2}$ " mandrel. The test is performed in the same manner as 94V with the above mentioned differences. The Material Classification criteria is also the same as 94V (see table 1) except that no specimens shall have flaming or glowing combustion up to a mark 125mm (5") from the bottom (free end) of the specimen.

It is usually advantageous to test materials using 94VTM instead of 94V because it is usually easier to pass or get a better rating as long as the material can be bent around the $\frac{1}{2}$ " mandrel.

UL will generally accept a VTM rating of similar level where a 94V material is required i.e., 94VTM-0 = 94V-0, 94VTM-1 = 94V-1, etc. UL does, however, reserve the right to make a determination on which rating a material should have based on the application.

94HBF, 94HF HORIZONTAL BURN – FOAM MATERIALS

Plastic foam materials that are less than $\frac{1}{2}$ " (13mm) in thickness such as foam tapes are tested using this method. Most foam tapes will not pass any of the vertical burn tests due to the

flammability of the adhesive. This test does not cover materials used for building construction or finishing.

The test uses a 2" x 6" specimen that is supported by wire cloth (screen) that is turned up at one end to keep the material in place during the flame application (fig.3). A flame is applied to the edge of the material that is against the up-turned edge of the wire cloth for 60 seconds then removed. Noted are the following:

- Duration of flaming and glowing combustion past the 1" (25mm) mark.
- Distance specimen burned.
- Whether or not cotton was ignited by flaming particles.

The material is classified **94HBF** if:

- The burning rate does not exceed 40mm per minute, **or**
- The specimen ceases to burn before reaching to a length of 125mm.

The material is classified **94HF-1** if all of the following are true:

- Flaming combustion for four out of a set of five specimens is ≤ 2 seconds.
- Flaming combustion for one out of a set of five specimens is ≤ 10 seconds.
- Glowing combustion for each specimen is ≤ 30 seconds.
- Cotton is not ignited by flaming particles.
- Burned length of each specimen is < 60 mm

If all the criteria for HF-1 above are met except that the cotton is ignited by flaming particles then the material is classified as **94HF-2**.

Fig. 3 SETUP FOR HORIZONTAL BURN FOR FOAM

